



MIKE GRAHAME & TYSON ANGUS
Personal Real Estate Corporation

HomeLife Benchmark Realty
Phone: 604.531.1111
sold@mikegrahame.com
www.mikegrahame.com

TOTAL FINISHED AREA: 1844 SQ.FT.

OTHER AREA(S)

GARAGE: 338 SQ.FT.
DECKS: 478 SQ.FT.*

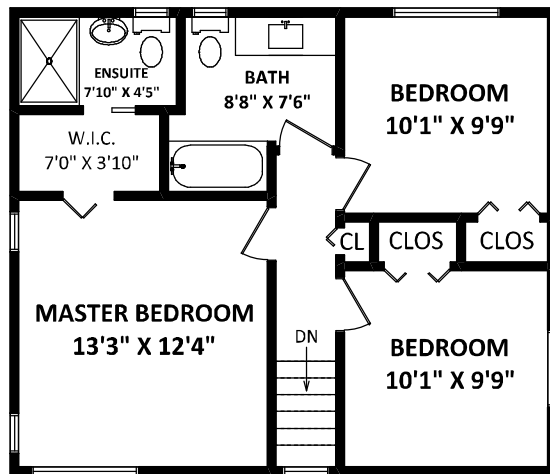
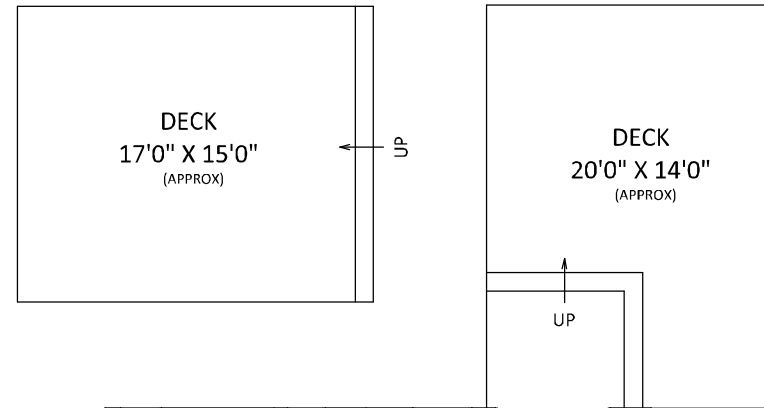

UPPER FLOOR: 627 SQ.FT.

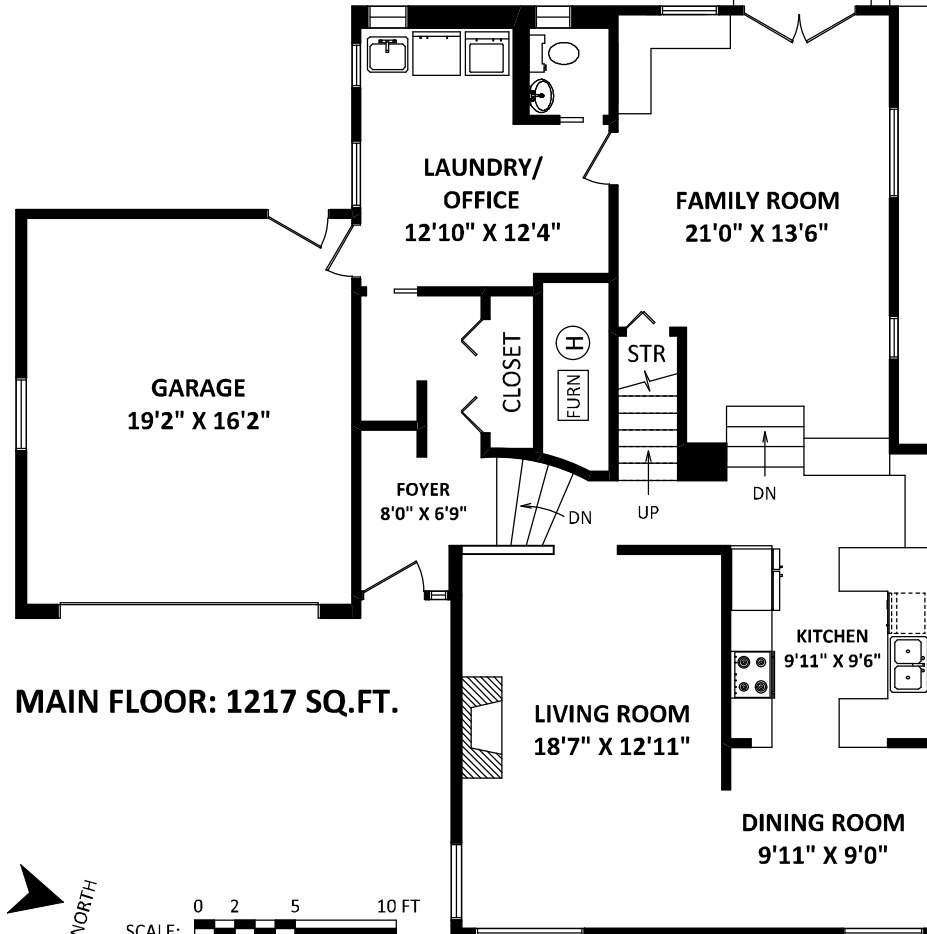

MAIN FLOOR: 1217 SQ.FT.

FLOOR PLAN BY: [NOVEMBER 3, 2016]

TEL: 604-575-1244
www.seevirtual360.com

DISCLAIMER:
1. MEASUREMENTS ARE FOR PROMOTIONAL USE ONLY & ARE NOT INTENDED FOR CONSTRUCTION USE.
ROOM DIMENSIONS ARE APPROXIMATE. MEASUREMENTS & CALCULATIONS FOR FINISHED AREAS ARE E&O INSURED.
2. FINISHED AREAS ARE ENCLOSED AREAS IN A HOUSE THAT ARE SUITABLE FOR YEAR-ROUNDED USE.
EMBOSSING WALLS, FLOORS, AND CEILING(S) THAT ARE SIMILAR TO THE REST OF THE HOUSE. (ANSI Z765-2003)
3. THIS FLOOR PLAN MAY ONLY BE REPRODUCED WITH PERMISSION OF THE REALTOR(S) ON THIS FLOOR PLAN.
* ANY MEASUREMENT WITH AN ASTERISK (*) OR (APPROX) ARE APPROXIMATE AND FOR ILLUSTRATION PURPOSES ONLY AND ARE NOT E&O INSURED.

